

### PURPOSE & DESCRIPTION

**Filtrex SiltSoxx<sup>®</sup> (Soxx) compost filter sock** is a three-dimensional tubular runoff and erosion control device used for Filtrex<sup>®</sup> Sediment traps - temporary **dry pond sediment containment detention systems** used to capture sediment and settle suspended solids in runoff from disturbed soils less than 5 acres (2 ha). Sediment traps are also used to capture sediment and settle suspended solids from **detention pond outfalls** and/or potential overflows. Sediment traps can be converted to, or retrofitted for, permanent (post-construction) Low Impact Development (LID) stormwater quality detention systems.

### APPLICATION

Sediment traps are typically installed down slope from disturbed soils where runoff capture and detention is feasible and settling of suspended solids is required; or where post-construction storm water runoff quality is a concern and pollutant reduction and/or LID practices are required.

Applications include:

- Individual sediment detention & containment zones where drainage areas do not exceed 5 acres (2 ha).
- Sediment and storm water detention pond outfall channels where additional removal of sediments and soluble pollutants are required before final discharge.
- Emergency overflow for retention or detention sediment or storm water containment systems.
- Where land area is limited or land disturbance, grading, and/or construction of a sediment pond is undesirable or not feasible.
- Where sediment particle sizes are predominantly greater than 0.002 mm (clay).
- Where post-construction storm water turbidity, TSS, phosphorus, nitrogen, bacteria, heavy metals, or petroleum hydrocarbons need to be removed prior to discharge or entry into receiving waters.

### ADVANTAGES AND DISADVANTAGES

#### Advantages

- Allows for trapping and settling of suspended solids without major excavation, land disturbance, or pond construction.
- Easily customized to fit most types of watersheds/drainage areas.
- Installation of sediment traps require no trenching, therefore soil is not disturbed upon installation or removal.
- Installation of sediment traps can reduce clearing, grubbing, and topsoil removal costs.
- Sediment traps can be installed year-round in difficult soil conditions such as frozen or wet ground, around/on top of sensitive tree roots, and dense and compacted soils, as long as stakes can be driven.
- Sediment traps function to disperse flow across the trap barrier, thereby reducing concentrated flows and recreating predevelopment flow patterns that mimic nature.
- Sediment traps are easily implemented as a treatment in a greater treatment train approach to erosion and sediment control.
- Organic matter and humus colloids in Filtrex<sup>®</sup> FilterMedia<sup>™</sup> (filler material in sediment traps) have the ability to bind and adsorb phosphorus, metals, and hydrocarbons that may be in storm water runoff.
- Microorganisms in FilterMedia have the ability to degrade organic pollutants and cycle captured nutrients in storm water runoff.
- Filtrex<sup>®</sup> Soxx (the mesh netting containment system) allows

sediment traps to be placed in areas of high concentrated flow.

- Sediment traps can be direct seeded at time of application to provide greater stability and filtration capability once vegetation is established.
- FilterMedia is organic and can be left on site after permanent stabilization is complete, to be used in landscape design and/or seeded and planted with permanent vegetation.
- FilterMedia improves existing soil structure if spread out and used as a soil amendment after construction activity is complete.
- Biodegradable or photodegradable Soxx can be left on site after construction activity and may eliminate the need for removal and labor and disposal costs.
- If vegetated and left on-site, sediment traps can be used to filter and infiltrate post-construction runoff.
- Sediment traps are less likely to obstruct wildlife movement and migration than planar/silt fence or sediment pond practices.
- Soxx for sediment traps are available in 8 in. (200mm), 12 in. (300mm), 18 in. (450mm), 24 in. (600mm), and 32 in. (800mm) diameters for customized applications and challenging situations.
- Sediment traps may assist in qualification for LEED<sup>®</sup> Green Building Rating and Certification credits under LEED Building Design & Construction (BD+C), New Construction v4. Awarded credits may be possible from the categories of Sustainable Sites, Water Efficiency, Materials & Resources, and Innovation. *Note: LEED is an independent program offered through the U.S. Green Building Council. LEED credits are determined on a per project basis by an independent auditing committee. Filtrex neither guarantees nor assures LEED credits from the use of its products. LEED is a trademark of the U.S. Green Building Council.*

#### Disadvantages

- If filler material of Soxx is not Filtrex<sup>®</sup> Certified<sup>SM</sup> FilterMedia<sup>™</sup>, performance may be diminished.
- If not installed correctly, maintained or used for a purpose or intention that does not meet specifications performance may be diminished.
- If sediment traps are not adequately sized to capture all runoff from the design watershed and/or storm overflow occurs, performance will be greatly diminished.
- If sediment particles sizes are less than 0.002 mm (clay), removal efficiency may be diminished unless significant detention time occurs. Additional additives can be used to target these smaller sediments.
- If land surface is extremely bumpy, rocky, or changes elevation

### ADVANTAGES

	LOW	MED	HIGH
<b>Installation Difficulty</b>		✓	
<b>Durability</b>			✓
<b>Sediment Control</b>			✓
<b>Runoff Flow Control</b>		✓	
<b>Life Cycle Cost</b>	✓		

abruptly ground surface contact to Soxx may be diminished thereby adversely effecting performance.

### MATERIAL SPECIFICATIONS

Sediment traps use only photodegradable or biodegradable Soxx netting materials available from Filtrexx International, and are the only mesh materials accepted in creating Filtrexx Sediment traps for any purpose. For Soxx tubular mesh material specifications see Table 9.1.

### FILTERMEDIA™ CHARACTERISTICS

Specifications for Filtrexx Sediment trap use only Filtrexx Certified FilterMedia which is a coarse composted material that is specifically designed for removal of solids and soluble pollutants from storm water runoff. *FilterMedia can be altered or customized to target specific pollutants in runoff as approved by the Engineer or Filtrexx International.* All Filtrexx Certified FilterMedia has been third party tested and certified to meet minimum performance criteria defined by Filtrexx International. Performance parameters include: hydraulic flow through rate, total solids removal efficiency, total suspended solids removal efficiency, turbidity reduction, nutrient removal efficiency, metals removal efficiency, and motor oil removal efficiency. For information on the physical and chemical properties of Certified FilterMedia refer to Certified FilterMedia Specifications in Section 5.1. Look for the Filtrexx Certified FilterMedia Seal from our international network of Filtrexx Certified Installers.

### PERFORMANCE

Performance testing and research on Sediment control has been extensive. For a summary of performance testing, research results, and design specifications see Table 1.2. For copies of publications, full reports, or Tech Link summaries contact Filtrexx International.

Successful bidders will furnish adequate research support showing their manufactured product meets or exceeds performance and design criteria outlined in this standard specification. Research or performance testing will be accepted if it meets the following criteria: conducted by a neutral third party, utilizes standard test methods reported by ASTM or referenced in a peer reviewed scientific journal, product and control treatments are tested in triplicate, performance results are reported for product and control (control should be a bare soil under the same set of environmental and experimental conditions), results are peer reviewed, results indicate a minimum 60% TSS removal efficiency and a minimum hydraulic flow through rate of 5 gpm/ft<sup>2</sup>. Bidders shall attach a copy of the research report indicating test methodologies utilized and results.

*Note: the Contractor is responsible for establishing a working erosion and sediment control system and may, with approval of the Engineer, work outside the minimum construction requirements as needed. Where the Sediment trap deteriorates or fails, it shall be repaired or replaced with an effective alternative.*

### DESIGN CRITERIA

Sediment traps are designed to temporarily *detain* sediment-laden runoff from disturbed soils prior to final stabilization.

The sediment and pollutant containment process characteristic to Sediment traps combines both filtering and deposition of suspended solids. Because Sediment trap is a *dry pond* system there is little or no re-suspension of settled particulates with successive runoff events and maintenance is generally lower relative to wet pond systems. Sediment traps also allow infiltration of detained storm

water, thereby reducing flow and pollutant loads, and disperse detained runoff across the trap barrier, reducing concentrated flows and mimicking predevelopment flow patterns. Installation and maintenance is especially important for proper function and performance. For engineering design details see Figure 9.1. For a summary of specifications for product/practice use, performance and design see Table 9.2.

### Site Orientation:

Sediment traps should be placed on low grade or level contours to maximize runoff-sediment volume containment. Flow of water should be perpendicular to the sediment trap at impact (See Figure 9.1). Placing sediment traps on compacted or undisturbed soil will reduce the potential for undermining. Sediment traps shall not be placed on fill soil or slopes. Backfilling with FilterMedia will also aid to reduce undermining potential.

In order to prevent water flowing around the ends of sediment traps, the ends of the sediment trap Soxx must be constructed pointing upslope so the ends are at a minimum 1 ft (30 cm) higher elevation than the lowest point (mid-section) of the sediment trap. The mid-section of the sediment trap shall be the point of lowest elevation. A minimum of 10 linear ft (3m) per end each placed at a 30 degree angle is recommended.

### Post-construction or Permanent Retrofits:

For long-term temporary or permanent post-construction or retrofitted systems Sediment traps can be direct-seeded to allow vegetation established directly in the Soxx. Vegetation on and around the sediment trap will assist in slowing runoff velocity for increased deposition and filtration of pollutants. Vegetated sediment trap may be left on site to filter and infiltrate post-construction storm water flows from developed and/or impervious surface areas. The option of adding vegetation will be at the discretion of the engineer. No additional soil amendments or fertilizer are required for vegetation establishment with the sediment trap system.

### Runoff Flow:

Runoff flow and ponding depth shall maintain a minimum 12 in (30 cm) vertical distance from the maximum waterline (freeboard) to the top of the sediment trap. Filtrexx Slope Interruption (Section 1.5) should be used to reduce the inflow energy of stormwater and Compost Erosion Control Blanket (Section 1.8) should be used to reduce the volume of sediment (and potentially runoff) flowing to the sediment trap. Filtrexx Runoff diversion (Section 1.6) should be used to divert runoff flowing from undisturbed and/or permanently stabilized areas to reduce design size requirement of the sediment trap. If concentrated flow is directed or channeled to sediment trap, energy flow dissipaters shall be used at the base of the channel/ concentrated flow prior to contact with Soxx. Dissipaters shall be placed at a minimum distance of 20 ft (6 m) from the base course of the sediment trap.

### Construction:

Sediment traps shall have a minimum effective height of 3 ft (90 cm) (or settling depth of 2 ft or 60 cm) to allow for deposition of suspended solids (Goldman et al., 1986). Additional height and runoff-sediment storage volume can be attained by excavating directly upslope from the sediment trap. Excavation shall not undermine the structure and integrity of the sediment trap system. For stability and ballast against constant water pressure (head) sediment traps shall have a 1H:1V construction ratio, although the

base may be wider for additional ballast. Larger diameter Soxx (18 in, 24 in, 32 in [450mm, 600mm, 800mm]) shall be used at the base of the sediment trap system with increasingly smaller diameter Soxx (8 in, 12 in, 18 in [200mm, 300mm, 450mm]) placed on top of the layer below (See Figure 7.1). Where Soxx are sleeved to join Soxx for long Sediment trap designs, material overlap shall be a minimum of 4 ft (120 cm) and shall be staked where material overlaps using 2 stakes, 2 ft (60 cm) apart. Soxx shall not be joined (sleeved) where concentrated flow contacts the Soxx or enters the sediment trap system. Additionally, sleeved joints shall not be located at elevation low points within the sediment trap.

#### Sediment Deposition:

Sediment basins and traps should generally remove sediments less 0.05 mm, although performance varies widely (Fifield, 2001).

While total suspended solids removal efficiency for Soxx is 78%, removal of fine silts (0.02 mm) and clays (0.002) typically requires storage time to allow for sediments to deposit within the water column (or ponded area). Typically, the longer the residence time and the greater the storage surface area the greater the removal of fine suspended solids. While fine sand may fall approximately 1 cm/sec, a silt particle will fall 1 cm/min, and a clay particle will fall 1 cm/5 hrs (Fifield, 2001). As an example, it takes a 0.001 mm clay particle 100 times as long to fall the same distance as a 0.01 silt particle (Fifield, 2001). Use Stoke's Law to calculate settling velocity of sediments by:

$$V_s = [g \times (s-1) \times d^2] \div (18 \times \mu)$$

Where:

$V_s$  = settling velocity (cm/sec)

$g$  = acceleration of gravity (980 cm/sec<sup>2</sup>)

$\mu$  = kinematic viscosity of a fluid (cm<sup>2</sup>/sec<sup>2</sup>)

$s$  = specific gravity of a particle

$d$  = diameter of a particle (cm)

#### Sizing and Design Area:

Sediment traps are typically defined as structures used to treat drainage areas less than 5 acres (2 ha); whereas, sediment basins are used for greater drainage areas (Goldman et al, 1986). Depending on known variables and considerations for design, there are several options for designing the size of a Sediment trap.

#### Option #1:

To determine the minimum constructed fascia area (length x height [from ground to max water line]) of Sediment trap required to prevent overflow, peak flow rate to the Sediment trap must be known or determined. Peak flow rate from a drainage area or small watershed can be determined using the Rational Formula:

$$Q = c \times i \times a$$

Where:

$Q$  = peak runoff flow rate

$c$  = runoff coefficient<sup>†</sup>

$i$  = rainfall intensity

$a$  = area of watershed/drainage area

Once  $Q$  (peak flow rate) is known the following equation can be used to design the required fascia area of Sediment trap to prevent overflow.

$$Q/5 = A$$

Where:

$Q$  = peak flow rate to Sediment trap (L/sec)

$5$  = flow through rate of Sediment trap<sup>\*\*</sup> (L/sec/m<sup>2</sup>)

$A$  = area of Sediment trap fascia (m<sup>2</sup>), [ $A$  = length (m) × depth of max water line (m)]

For English Units:

$$Q/0.984 = A$$

Where:

$Q$  = peak flow rate to Sediment trap (cfm)

$0.984$  = flow through rate of Sediment trap<sup>\*\*</sup> (cfm/ft<sup>2</sup>)

$A$  = area of Sediment trap fascia (ft<sup>2</sup>), [ $A$  = length (ft) × depth of max water line (ft)]

\* See Section 2.1 Stormwater Blanket Specification and Design for runoff coefficient for this Filtrexx BMP

\*\* Includes safety factor for minor compacting during construction and sediment accumulation behind barrier.

#### Option #2:

The USEPA (1998) requires that sediment containment systems be designed to capture runoff from the 2 yr 24 hr rainfall event. For the eastern half of the US this ranges from 2 in (50 mm) to 6 in (150 mm) of rainfall, with an average of 3 in (75 mm) (SCS, 1986). The USEPA (1998) requires that only the first 1 in (25 mm) of runoff be contained for a 3 in (75 mm) storm; for 1 acre this is equivalent to 3600 ft<sup>3</sup> (252 m<sup>3</sup>/ha). Under this design scenario, 3600 ft<sup>3</sup> runoff per drainage acre must be contained. Consult the Soil Conservation Service (1986) 2-yr 24-hr map for the design storm event value for your region.

#### Option #3:

This option may be used to determine minimum runoff volume containment, height of Sediment trap, or storage surface area if 2 of the variables are known (Fifield, 2001).

$$Q = D \times A$$

Where:

$Q$  = runoff volume (m<sup>3</sup>)

$D$  = depth of max water line (m)

$A$  = surface area of containment (m<sup>2</sup>)

#### Option #4:

Settling velocity of sediment can have an effect on runoff storage capacity for the Sediment trap. If settling velocity is known (Stoke's Law), and the outflow rate of the containment system is known, minimum surface area of containment can be determined by:

$$SA = (120 \times Q) \div V_s$$

Where:

$SA$  = minimum surface area (m<sup>2</sup>)

$Q$  = outflow rate of containment system (m<sup>3</sup>/sec)

$V_s$  = settling velocity of sediment particle (cm/sec)

#### INSTALLATION

1. Sediment traps shall meet Filtrexx Soxx Mesh Material and Filtrexx Certified FilterMedia specifications.
2. Call Filtrexx at 877-542-7699 or visit [www.filtrexx.com](http://www.filtrexx.com) for a current list of installers and distributors of Filtrexx products.
3. Sediment traps will be placed at locations indicated on plans as directed by the Engineer.
4. Sediment traps shall not be placed on fill soil or slopes, soft, or uneven ground.

5. Sediment traps must be installed on level contours. Field verification with laser level is strongly recommended.
6. Sediment traps should be installed at the base of the drainage area.
7. Filtrexx Runoff Diversion can be installed to divert runoff flows from undisturbed or stabilized areas from entering design area of sediment trap.
8. Filtrexx Slope Interruption may be installed upslope and with the runoff flow path to reduce flow energy entering sediment traps.
9. Concentrated flows, channels, or ditches directing flow into sediment traps shall employ energy flow dissipaters prior to flow contact with Soxx or entry into the sediment trap system. Dissipaters shall be placed at a minimum distance of 20 ft (6 m) from the base course of the sediment trap.
10. Sediment traps shall be installed so the effective height is at least 3 ft (90 cm).
11. Ends of sediment traps shall be at least 1 ft (30cm) higher in elevation than the mid-section. The mid-section shall be the lowest point of the trap.
12. Sediment traps shall be constructed so the horizontal base width is at least equivalent to the effective height (1H:1V).
13. Sediment traps sized and specified by fascia design area shall be installed so that the height is measured vertically not across the plane of the sediment trap face.
14. Additional runoff-sediment storage area can be created by over excavating the area immediately upslope of the sediment trap.
15. Soxx that are sleeved to create longer lengths shall not be placed in areas of concentrated flow, at the base of channels/ditches, or at the low point with the sediment trap system.
16. Soxx that are sleeved to create longer lengths shall be overlapped by a minimum of 4 ft (120 cm) and shall be staked where material over laps using 2 stakes 2 ft (60 cm) apart.
17. Stakes shall be installed through the middle of the Soxx using 2 in (50mm) by 2 in (50mm) by 3 ft (1m) wooden hardwood stakes on 10 ft (3 m) centers; 5 ft (1.5 m) on center staking may be used to increase stability. Stakes shall be placed in a pyramid configuration perpendicular to Soxx where stakes cross at the apex of the sediment trap. Stakes shall be joined and secured with wire wrapping at apex using 16 gauge or multi-strand 20 gauge wire allowing 12 in (30cm) of stake above the Soxx. All base layers shall be staked on 5 ft (1.5 m) centers. All base layers shall be staked on 5 ft (1.5 m) centers; placed opposite the pyramid staking; where staking is present every 2.5 ft (0.75 m). Half inch (12.5 mm) rebar may also be used when ground is frozen or extremely compacted.
18. Staking depth for all soil types shall be minimum 12 in (300mm) into native soil.
19. Soxx to receive additional layers shall be slightly compacted and leveled.
20. Loose FilterMedia shall be backfilled along the upslope side of the sediment trap, along seams, and within void spaces; thereby filling the seam between the soil surface and the sediment trap, improving sediment containment, and reducing undercutting potential.
21. If the sediment trap is to be left as a permanent filter or part of the natural landscape, it may be seeded at time of installation for establishment of permanent vegetation. The Engineer will specify seed requirements.
22. Sediment traps are not to be used in perennial, ephemeral, or intermittent streams.

See design drawing schematic for correct sediment trap installation (Figure 9.1).

### INSPECTION

Routine inspection should be conducted within 24 hrs of a runoff event or as designated by the regulating authority. Sediment traps should be regularly inspected to make sure they maintain their shape and are producing adequate hydraulic flow-through. If ponding becomes excessive, additional sediment traps may be required to reduce effective drainage area or sediment removal may be necessary. Sediment traps shall be inspected until area above has been permanently stabilized and construction activity has ceased.

### MAINTENANCE

1. The Contractor shall maintain the sediment trap in a functional condition at all times and it shall be routinely inspected.
2. If the sediment trap has been damaged, it shall be repaired, or replaced if beyond repair.
3. The Contractor shall remove sediment at the base of the upslope side of the sediment trap when accumulation has reached 1/2 of the effective height of the sediment trap, or as directed by the Engineer. Alternatively, a new Soxx can be placed on top of the original structure creating more sediment storage capacity without soil disturbance.
4. Sediment traps shall be maintained until disturbed area above the device has been permanently stabilized and construction activity has ceased.
5. The FilterMedia will be dispersed on site once disturbed area has been permanently stabilized, construction activity has ceased, or as determined by the Engineer.
6. For long-term sediment and pollution control applications, sediment traps can be seeded at the time of installation to create a vegetative filtering system for prolonged and increased filtration of sediment and soluble pollutants (contained vegetative filter strip). The appropriate seed mix shall be determined by the Engineer.

### DISPOSAL/RECYCLING

FilterMedia is a composted organic product recycled and manufactured from locally generated organic, natural, and biologically based materials. Once all soil has been stabilized and construction activity has been completed, the FilterMedia may be dispersed with a loader, rake, bulldozer or similar device and may be incorporated into the soil as an amendment or left on the soil surface to aid in permanent seeding or landscaping. Leaving the FilterMedia on site reduces removal and disposal costs compared to other sediment control devices. The mesh netting material will be extracted from the FilterMedia and disposed of properly by the Contractor. The photodegradable mesh netting material (Soxx) may degrade if left on site. Biodegradable mesh netting material is available and may eliminate the need and cost of removal and disposal.

### METHOD OF MEASUREMENT

Bid items shall show measurement as 8 (200), 12 (300), 18 (450), 24 (600), 32 (800) inch (mm) diameter Filtrexx® Sediment Trap Soxx/SiltSoxx per linear foot (or linear meter) specified layer, or Filtrexx Sediment trap per square ft (or square meter) installed.

Engineer shall notify Filtrexx of location, description, and details of project prior to the bidding process so that Filtrexx can provide design aid and technical support.

**FIELD APPLICATION PHOTO REFERENCES**



Use at Basin Outfall.



Large Sediment Storage Capacity.



Stacking Method for Sediment Traps.



Use at the base of a channel or swale prior to final discharge

**ADDITIONAL INFORMATION**

For other references on this topic, including additional research reports and trade magazine and press coverage, visit the Filtrexx website at [filtrexx.com](http://filtrexx.com)

Filtrexx International, Technical Support  
 877-542-7699 | [www.filtrexx.com](http://www.filtrexx.com) | [info@filtrexx.com](mailto:info@filtrexx.com)  
 Call for complete list of international installers and distributors.

the branch & leaf logo®, EnviroSoxx®, Filtrexx®, Filtrexx SiltSoxx®, GreenLoxx®, GroSoxx®, and the color GREEN®, are Registered Trademarks used by Filtrexx International.

CECB™ [Compost Erosion Control Blanket], CSWB™ [Compost StormWater Blanket], DitchChexx™, EdgeSaver™, FilterCell™, FilterMedia™, FilterSoxx™, GrowingMedia™, InletSoxx™, LivingWall™, and Lockdown™, are Trademarks used by Filtrexx International.

Filtrexx Certified<sup>SM</sup> and its accompanying logo are Service Marks used by Filtrexx International.

The information contained herein may be subject to confidential intellectual property of Filtrexx International, including but not limited to US Patents 7,226,240; 7,452,165; 7,654,292; 8,272,812; 8,439,607; 8,740,503; 8,821,076; 9,044,795; 9,945,090; and 9,982,409 or Patents Pending and is the property of Filtrexx International.

Copyright 2005-2021, Filtrexx International, all rights reserved. Unauthorized reproduction prohibited. All statements, product characteristics, and performance data contained herein are believed to be reliable based on observation and testing, but no representations, guarantees, or warranties of any kind are made as to accuracy, suitability for particular applications, or the results to be obtained. Nothing contained herein is to be considered to be permission or a recommendation to use any proprietary process or technology without permission of the owner. No warranty of any kind, expressed or implied, is made or intended.

**REFERENCES CITED & ADDITIONAL RESOURCES**

- American Association of State Highway Transportation Officials. 2003. Standard Specification for Transportation Materials and Methods of Sampling and Testing, Designation M9-03, Compost for Erosion/Sediment Control. Washington, DC
- Faucette, L.B., K. Kerchner, and A. Vick. 2006. Sediment Storage Capacity of SiltSoxx™ vs. Silt Fence. Filtrexx® Tech Link #3314.
- Faucette, L.B., H. Keener, M Klingman, and K. Kerchner. 2006. Design Capacity Prediction Tool for SiltSoxx™ and Silt Fence. Filtrexx® Tech Link #3313 (Description of Design Tool) and Filtrexx® Library #301 (Design Tool).
- Faucette, L.B. 2006. Flow-Through Rate, Design Height, and Design Capacity of SiltSoxx™ and Silt Fence. Filtrexx® Tech Link #3304.
- Faucette, L.B. 2006. Design Height, Flow-Through Rate, and Slope Spacing of SiltSoxx™ and Silt Fence. Filtrexx® Tech Link #3311.
- Faucette, L.B., and R. Tyler. 2006. Organic BMPs used for Storm Water Management. Proceedings of the International Erosion Control Association Annual Conference, Long Beach, CA 2006.
- Faucette, B, F. Shields, and K. Kurtz. 2006. Removing storm water pollutants and determining relations between hydraulic flow-through rates, pollutant removal efficiency, and physical characteristics of compost filter media. Second Interagency Conference on Research in Watersheds, 2006 Proceedings. Coweeta Hydrologic Research Station, NC. Filtrexx® Library #106.
- Faucette, B., Sadeghi, A., and K. Sefton. 2006. USDA ARS - Evaluation of Compost Filter Socks and Silt Fence in Sediment and Nutrient Reduction from Runoff. Filtrexx® Tech Link #3308
- Faucette, L.B. and A. Vick. 2006. LEED Green Building Credits using Filtrexx® Organic BMPs. Filtrexx® Tech Link #3301.
- Faucette, L.B. A. Vick, and K. Kerchner. 2006. Filtrexx®, Compost, Low Impact Development (LID), and Design Considerations for Storm Water Management. Filtrexx® Tech Link #3306.
- Faucette L.B., C.F. Jordan, L.M. Risse, M. Cabrera, D.C. Coleman, and L.T. West. 2005. Evaluation of Storm Water from Compost and Conventional Erosion Control Practices in Construction Activities. *Journal of Soil and Water Conservation*. 60:6: 288-297.
- Faucette, L.B. 2005. Removal and Degradation of Petroleum Hydrocarbons from Storm Water with Compost. Filtrexx® Tech Link #3307.
- Faucette, L.B. 2005. A Comparison of Performance and Test Methods of SiltSoxx™ and Silt Fence. Filtrexx® Tech Link #3302.
- Faucette, L.B., N. Strazar, A. Marks. 2006. Filtrexx® Polymer and Flocculent Guide. Filtrexx® Library #601.
- Fifield, J. 2001. Designing for Effective Sediment and Erosion Control on Construction Sites. Forester Press, Santa Barbara, CA.
- Goldman, S. J., K. Jackson, and T.A. Bursztynsky. 1986. Erosion and Sediment Control Handbook. McGraw-Hill Book Company, New York, NY.
- Keener, H., B. Faucette, and M. Klingman. 2006. Flow-through rates and evaluation of solids separation of compost filter media vs. silt fence in sediment control applications. 2006 American Society of Agricultural and Biological Engineers Annual International Conference, Portland, OR. Paper No. 062060.
- Marks, A., R. Tyler, and B. Faucette. 2005. The Filtrexx® Library. Digital publication of support tools for the erosion industry. [www.filtrexx.com](http://www.filtrexx.com).
- Marks, A., and R. Tyler. 2003. Filtrexx® International Company Website. Specifications, CAD drawings, case histories. [www.filtrexx.com](http://www.filtrexx.com).
- Sadhegi, A., K. Sefton, and B. Faucette. 2006. Sediment and nutrient removal from storm water with compost filter socks and silt fence. 2006 American Society of Agricultural and Biological Engineers Annual International Conference, Portland, OR. Paper No. 06XXXX.
- Soil Conservation Service. 1986. Urban Hydrology for Small Watershed. Technical Release 55. US Department of Agriculture.
- Tyler, R.W., and A. Marks. 2004. Erosion Control Toolbox CD Kit. A Guide to Filtrexx® Products, Educational Supplement, and Project Videos. 3 CD set for Specifications and Design Considerations for Filtrexx® Products.
- Tyler, R.W., and A. Marks. 2003. Filtrexx® Product Installation Guide. Grafton, Ohio.
- Tyler, R.W., and A. Marks. 2003. A Guide to Filtrexx® Products. Product Descriptions and Specifications for Filtrexx® Products.
- Tyler, R.W., J. Hoeck, and J. Giles. 2004. Keys to Understanding How to Use Compost and Organic Matter. IECA Annual Meeting Presentations published as IECA Digital Education Library, Copyright 2004 Blue Sky Broadcast.
- Tyler, R.W. 2004. International PCT Patent Publication #: WO 2004/002834 A2. Containment Systems, Methods and Devices for Controlling Erosion. Patent Application Filed on January 8, 2004.
- Tyler, R.W. 2003. International PCT Application #: PCTUS2003/020022. Containment Systems, Methods and Devices for Controlling Erosion. Patent Application Filed on June 25, 2003.
- Tyler, R.W. 2003. US Patent Publication #: 2003/0031511 A1. Devices, Systems and Methods for Controlling Erosion. Patent Application Filed on January 13, 2003.
- Tyler, R.W. 2002. US Patent Application #10/208,631. Devices, Systems and Methods for Controlling Erosion. Patent Application Filed on July 31, 2001.
- Tyler, R.W. 2001. Provisional Patent Application #60/309,054. Devices, Systems and Methods for Controlling Erosion. Patent Application Filed on July 31, 2001.
- Tyler, R.W. 2001. Filtrexx® Product Manual. Specifications and Design Considerations for Filtrexx® Products, Grafton, OH.
- Tyler, R.W. 1996. Winning the Organics Game – The Compost Marketers Handbook. ASHS Press, ISBN # 0-9615027-2-x.
- Tyler, R.W. 2007. US Patent # 7,226,240 “Devices, Systems and Methods for Controlling Erosion” Issue date 6-5-07.
- USEPA NPDES Phase II. 2006. Compost Filter Socks: Construction Site Storm Water Runoff Control. National Menu of Best Management Practices for Construction Sites. [http://cfpub.epa.gov/npdes/stromwater/menuofbmps/con\\_site.cfm](http://cfpub.epa.gov/npdes/stromwater/menuofbmps/con_site.cfm).
- USEPA. 1998. Reissuance of NPDES General Permits for Storm Water Discharges from Construction Activities. Federal Register, Part II, Notice. US Government Printing Office, Washington, DC.

**Table 9.1.** Filtrexx SiltSoxx® Material Specifications.

Material Type	NATURAL ORIGINAL (Cotton Fiber)	NATURAL PLUS (Wood Fiber)	BASIC (5 mil High Density Polyethylene HDPE)	BASIC PLUS (Multi-Filament Polypropylene MFPP)	DURABLE (Multi-Filament Polypropylene MFPP)	ORIGINAL / DURABLE PLUS / DURASOXX HD (Multi-Filament Polypropylene MFPP)	EXTREME (Multi-Filament Polypropylene MFPP)
Material Characteristic	Biodegradable	Biodegradable	Photodegradable	Photodegradable	Photodegradable	Photodegradable	Photodegradable
Design Diameters	5 in (125mm), 8 in (200mm), 12 in (300mm)	5 in (125mm), 8 in (200mm), 12 in (300mm)	8 in (200mm), 12 in (300mm), 18 in (400mm)	8 in (200mm), 12 in (300mm), 18 in (400mm), 24 in (600mm), 32 in (800mm)	5 in (125mm), 8 in (200mm), 12 in (300mm), 18 in (400mm), 24 in (600mm), 32 in (800mm)	5 in (125mm), 8 in (200mm), 12 in (300mm), 18 in (400mm), 24 in (600mm)	8 in (200mm), 12 in (300mm)
Mesh Opening	1/8 in (3mm)	1/8 in (3mm)	3/8 in (10mm)	3/8 in (10mm)	1/8 in (3mm)	1/8 in (3mm)	1/16 in (1.5mm)
Tensile Strength (ATSM D4595) <sup>1</sup>	MD: 193 lbs TD: 158 lbs	MD: 210 lbs TD: 289 lbs	MD: 211 lbs TD: 79 lbs	MD: 236 lbs TD: 223 lbs	MD: 545 lbs TD: 226 lbs	MD: 670 lbs TD: 423 lbs	MD: 1062 lbs TD: 797 lbs
% Original Strength from Ultraviolet Exposure (ASTM G-155)	ND	ND	23% at 1000 hr	100% at 1000 hr	100% at 1000 hr	100% at 1000 hr	100% at 1000 hr
Functional Longevity/ Project Duration <sup>2</sup>	up to 12 months <sup>3</sup>	up to 18 months <sup>4</sup>	up to 4 yr	up to 4 yr	up to 5 yr	up to 5 yr	up to 5 yr

<sup>1</sup>Tensile Strength is based on 12" diameter using ATSM D4595. See Filtrexx TechLink #3342 for full tensile strength testing.

<sup>2</sup>Functional longevity ranges are estimates only. Site specific environmental conditions may result in significantly shorter or longer time periods.

<sup>3</sup>Data based on Caltrans research and specifications

<sup>4</sup>See TechLink #3339 for research & testing

**Table 9.2.** Filtrex® Sediment Trap Performance and Design Specifications Summary.

Design Diameter	8 in (200mm)	12 in (300mm)	18 in (450mm)	24 in (600mm)	32 in (800mm)	Testing Lab/ Reference	Publication(s)
	Design & Performance						
Effective Height	6.5 in (160mm)	9.5 in (240mm)	14.5 in (360mm)	19 in (480mm)	26 in (650mm)	The Ohio State University, Ohio Agricultural Research and Development Center	Transactions of the American Society of Agricultural & Biological Engineers, 2006
Effective Circumference	25 in (630mm)	38 in (960mm)	57 in (1450mm)	75 in (1900mm)	100 in (2500mm)		
Density (when filled)	13 lbs/ft (20 kg/m)	32 lbs/ft (50 kg/m)	67 lbs/ft (100 kg/m)	133 lbs/ft (200 kg/m)	200 lbs/ft (300 kg/m)	Soil Control Lab, Inc	
Air Space	20%	20%	20%	20%	20%	Soil Control Lab, Inc	
Maximum continuous length	unlimited	unlimited	unlimited	unlimited	unlimited		
Staking Requirement	10 ft (3m)	10 ft (3m)	10 ft (3m)	10 ft (3m)	10 ft (3m)		
Maintenance Requirement (sediment accumulation removal at X height)	3.25 in (80mm)	4.75 in (120mm)	7.25 in (180mm)	9.5 in (240mm)	13 in (325mm)		
Initial Maintenance Requirement based on Rainfall-Runoff	22 in (55 cm); 1109 L/linear m	32 in (80 cm); 1388 L/linear m	42 in (105 cm); 1825 L/linear m	64 in (160 cm); 2776 L/linear m	86 in (215 cm); 3885 L/linear m	The University of Georgia & Auburn University	
Functional Longevity**	6 mo – 5 yr	6 mo – 5 yr	6 mo – 5 yr	6 mo – 5 yr	6 mo – 5 yr		
Maximum Slope Length (<2%)	600 ft (183m)	750 ft (229m)	1000 ft (305m)	1300 ft (396m)	1650 ft (500m)	The Ohio State University, Ohio Agricultural Research and Development Center	Filtrex Design Tool, Filtrex Library #301, Filtrex Tech Link #3304 & #3311
Hydraulic Flow Through Rate	7.5 gpm/ft (94 L/min/m)	11.3 gpm/ft (141 L/min/m)	15.0 gpm/ft (188 L/min/m)	22.5 gpm/ft (281 L/min/m)	30.0 gpm/ft (374 L/min/m)	The Ohio State University, Ohio Agricultural Research and Development Center; University of Guelph, School of Engineering/ Watershed Research Group	Filtrex Tech Link #3311 & #3313, #3308; American Society of Agricultural & Biological Engineers Meeting Proceedings, 2006, Second Interagency Conference on Research in Watersheds, 2006
P Factor (RUSLE)	0.1-0.32	0.1-0.32	0.1-0.32	0.1-0.32	0.1-0.32	USDA ARS Environmental Quality Lab/ University of Georgia	American Society of Agricultural & Biological Engineers Meeting Proceedings, 2006
Sediment Storage Capacity***	174 cu. in (2850cc)	396 cu. in (6490cc)	857 cu. in (14040cc)	1631 cu. in (26840cc)	2647 cu. in (43377 cc)		Filtrex Tech Link #3314
Total Solids Removal	98%	98%	98%	98%	98%	Soil Control Lab, Inc	International Erosion Control Association, 2006
Total Suspended Solids Removal	78%	78%	78%	78%	78%	USDA ARS Environmental Quality Lab	Filtrex Tech Link #3308; American Society of Agricultural & Biological Engineers Meeting Proceedings, 2006
Turbidity Reduction	63%	63%	63%	63%	63%	USDA ARS Environmental Quality Lab	Filtrex Tech Link #3308; American Society of Agricultural & Biological Engineers Meeting Proceedings, 2006
Clay (<0.002mm) Removal	65%	65%	65%	65%	65%	USDA ARS Environmental Quality Lab	Filtrex Tech Link
Silt (0.002-0.05mm) Removal	64%	64%	64%	64%	64%	USDA ARS Environmental Quality Lab	Filtrex Tech Link
Other Recommended Uses	Inlet Protection, Ditch Protection, Slope Interruption	Inlet protection, Ditch Protection, Concrete Washout, Filtration System, Slope Interruption	Ditch Protection, Concrete Washout, Filtration System	Ditch Protection, Concrete Washout, Filtration System	Ditch Protection, Concrete Washout, Filtration System		

\* Based on rainfall intensity of 12.5 cm (5 in)/hr applied to a bare clay loam soil at a 10% slope; runoff flow rate of 108 ml/sec/linear m (0.52 gpm/linear ft); and mean runoff volume of 230 L/m<sup>2</sup> (6.3 g/ft<sup>2</sup>).  
 \*\* Functional Longevity is dependent on mesh material type, UV exposure, freeze/thaw frequency, region of US/Canada, runoff-sediment frequency/duration/loading, and adherence to specified maintenance requirement. Functional longevity ranges are estimates only. Site specific environmental conditions may result in significantly shorter or longer time periods.  
 \*\*\* Sediment Storage Capacity = sediment accumulation behind (directly upslope) + within the device.



Figure 9.1. Engineer Design Drawing for Sediment Trap.

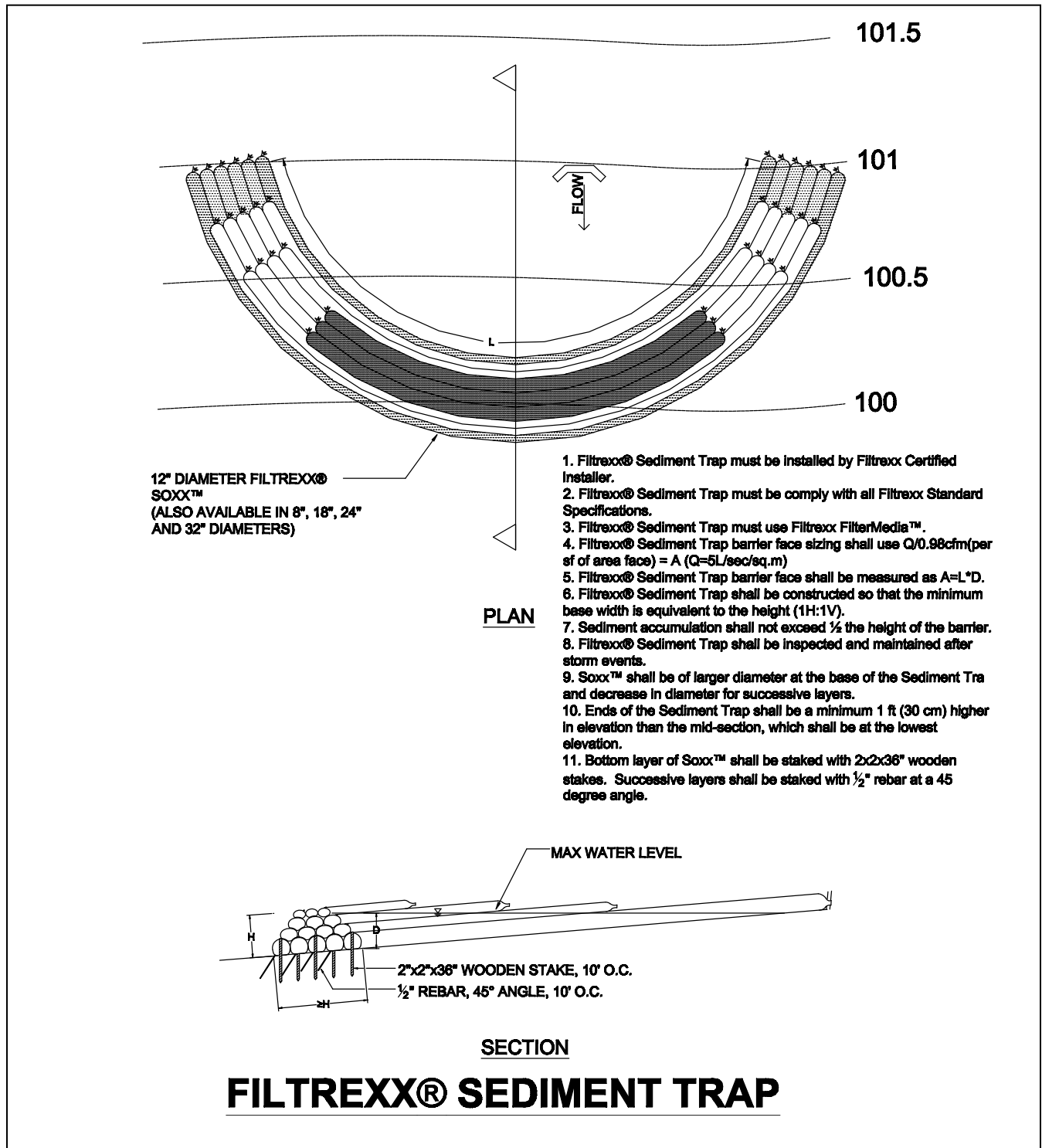

**Figure 9.2.** Engineer Design Detail for Staking Sediment Traps.

