

6.1.4 Concrete Washout - Compost Filter Sock

PURPOSE & DESCRIPTION

Filtrex SiltSoxx® (Soxx) compost filter sock is a three-dimensional tubular **solids separation and water pollutant filtration** device used as a **Concrete Washout** for temporary, passive filtration of sediment-laden effluent and point sources of contaminated water.

APPLICATION

Concrete washouts are used in temporary applications where unfiltered slurry or effluent may adversely affect surface water quality. Common applications for Concrete washouts include:

- Concrete wash-off and wash-out from equipment and trucks.
- Pumping of surface water to allow access to stream banks for stabilization projects.
- Sediment and storm water pond emergency overflow capture and filtration.
- Dredging slurry filtration.
- Animal manure and lagoon slurry filtration at concentrated animal feeding operation (CAFO) sites.
- Non-hazardous industrial effluent and slurry solids separation from point sources.

Concrete washouts require adequate site drainage space to allow water to percolate through the concrete washout and drain away from the device, leaving the solid fraction or filtrate within the device. After the water has been separated, the solid portion can be removed with a loader and disposed or land applied, depending upon the constituents within the filtrate. On sites with highly permeable soils, high water tables, or if constituents in unfiltered water may contaminate soil or ground water, an impervious mat or membrane may be placed underneath the concrete washout to prevent soil infiltration and percolation of contaminated water. Passively dewatering solids-laden water prior to hauling and disposal can significantly reduce handling and disposal costs.

INSTALLATION

1. Concrete washouts used for solids separation and filtration of soluble pollutants from contaminated water shall meet Filtrex Soxx Mesh Material and Filtrex Certified FilterMedia specifications.
2. Call Filtrex at 877-542-7699 or visit www.filtrex.com for a current list of installers and distributors of Filtrex products.
3. Concrete washouts shall be placed at locations indicated on plans as directed/specified by the Engineer. Concrete washouts should be installed in a manner that effectively filters solids and soluble pollutants from contaminated water.
4. Concrete washouts may be manufactured onsite at time of application or pre-manufactured and delivered to site for installation.
5. Installation of concrete washouts shall ensure that the containment area within the concrete washout is sufficient to handle the rate and volume of contaminated influent water.
6. Installation of concrete washouts shall ensure that the containment area within the concrete washout is sufficient to allow for receiving water to properly flow through the filter concrete washout filtration system.
7. Stakes shall be installed through the middle of the concrete washout on 5 ft (1.5m) centers, using 2 in (50mm) by 2 in (50mm) by 3 ft (1m) wooden stakes.

8. Staking depth for sand and silt loam soils shall be 12 in (300mm), and 8 in (200mm) for clay soils.
9. Standard diameter size of concrete washouts for concrete washouts is 18 in (450mm). For applications where rate or volume of contaminated water addition is high the Engineer may specify 24 in (600mm) or 32 in (800mm) diameter concrete washouts, a stack design, or an equilateral triangle or pyramid design.
10. If stack or pyramid design is specified, concrete washout Soxx should decrease in diameter with each layer of concrete washout Soxx.
11. Concrete washouts may be installed on top of impermeable mats or membranes to prevent percolation of contaminated water into soil. Local ordinances may require the use of additives to reduce ph contamination in runoff.
12. Concrete washouts shall not be placed near concentrated or high sheet flows of storm runoff which may compromise the structural base of the concrete washout.
13. Vegetated concrete washouts may be seeded at the time of manufacture and installation to create a contained 'green or living bio-filter'. These may be left intact once construction phase is complete. The appropriate seed mix, live stakes, and/or sprigs shall be specified by the Engineer.
14. Concrete washouts installed on paved surfaces should be stabilized along the outer circumference using concrete blocks for structural support.

INSPECTION & MAINTENANCE

Routine inspection should be conducted within 24 hrs of a runoff event or as designated by the regulating authority. Concrete washouts should be regularly inspected to make sure they maintain their shape and are producing adequate hydraulic flow-through and solids removal. If rainfall becomes excessive, additional concrete washouts may be required to contain the added water volume. Water height within the concrete washouts should remain 4 in below the lowest point of the rim to allow for storm water volume additions. If overflow, undercutting, or leaking between concrete washouts occurs, maintenance should be conducted immediately.

1. The contractor shall maintain the concrete washouts in a functional condition at all times and it shall be routinely inspected.
2. If a concrete washout has been damaged, it shall be repaired, or replaced if beyond repair.
3. The contractor shall remove solids or filtrate from the inside of the concrete washout when solids accumulation has reached 1/2 of the effective height of the concrete washout, or as directed by the engineer. As an alternative, another concrete washout may be installed on top of, or in a pyramid design to increase the containment capacity of the concrete washout.
4. If concrete washouts become clogged with debris or solids, they shall be maintained so as to assure proper hydraulic flow through. Overflow or undercutting of contaminated water is not acceptable.
5. If minor undercutting occurs, the areas may be plugged with sand, soil or additional FilterMedia. If undercutting continues, a new concrete washout should be installed and leveling or minor grading of ground surface may be required to increase surface contact with concrete washout.
6. Concrete washouts shall be maintained until contaminated water has fully percolated through the device.

7. The FilterMedia and filtrate may be dispersed on site once solids separation is complete only if there are no concerns with soil and water contamination, or as determined by the engineer.

ADDITIONAL INFORMATION

For other references on this topic, including additional research reports and trade magazine and press coverage, visit the Filtrexx website at filtrexx.com

Filtrexx International, Technical Support
877-542-7699 | www.filtrexx.com | info@filtrexx.com
Call for complete list of international installers and distributors.

the branch & leaf logo®, EnviroSoxx®, Filtrexx®, Filtrexx SiltSoxx®, GreenLoxx®, GroSoxx®, and the color GREEN®, are Registered Trademarks used by Filtrexx International.

CECB™ [Compost Erosion Control Blanket], CSWB™ [Compost StormWater Blanket], DitchChexx™, EdgeSaver™, FilterCell™, FilterMedia™, FilterSoxx™, GrowingMedia™, InletSoxx™, LivingWall™, and Lockdown™, are Trademarks used by Filtrexx International.

Filtrexx CertifiedSM and its accompanying logo are Service Marks used by Filtrexx International.

The information contained herein may be subject to confidential intellectual property of Filtrexx International, including but not limited to US Patents 7,226,240; 7,452,165; 7,654,292; 8,272,812; 8,439,607; 8,740,503; 8,821,076; 9,044,795; 9,945,090; and 9,982,409 or Patents Pending and is the property of Filtrexx International.

Copyright 2005-2021, Filtrexx International, all rights reserved. Unauthorized reproduction prohibited. All statements, product characteristics, and performance data contained herein are believed to be reliable based on observation and testing, but no representations, guarantees, or warranties of any kind are made as to accuracy, suitability for particular applications, or the results to be obtained. Nothing contained herein is to be considered to be permission or a recommendation to use any proprietary process or technology without permission of the owner. No warranty of any kind, expressed or implied, is made or intended.

Figure 4.1. Engineering Design Drawing for Concrete Washout

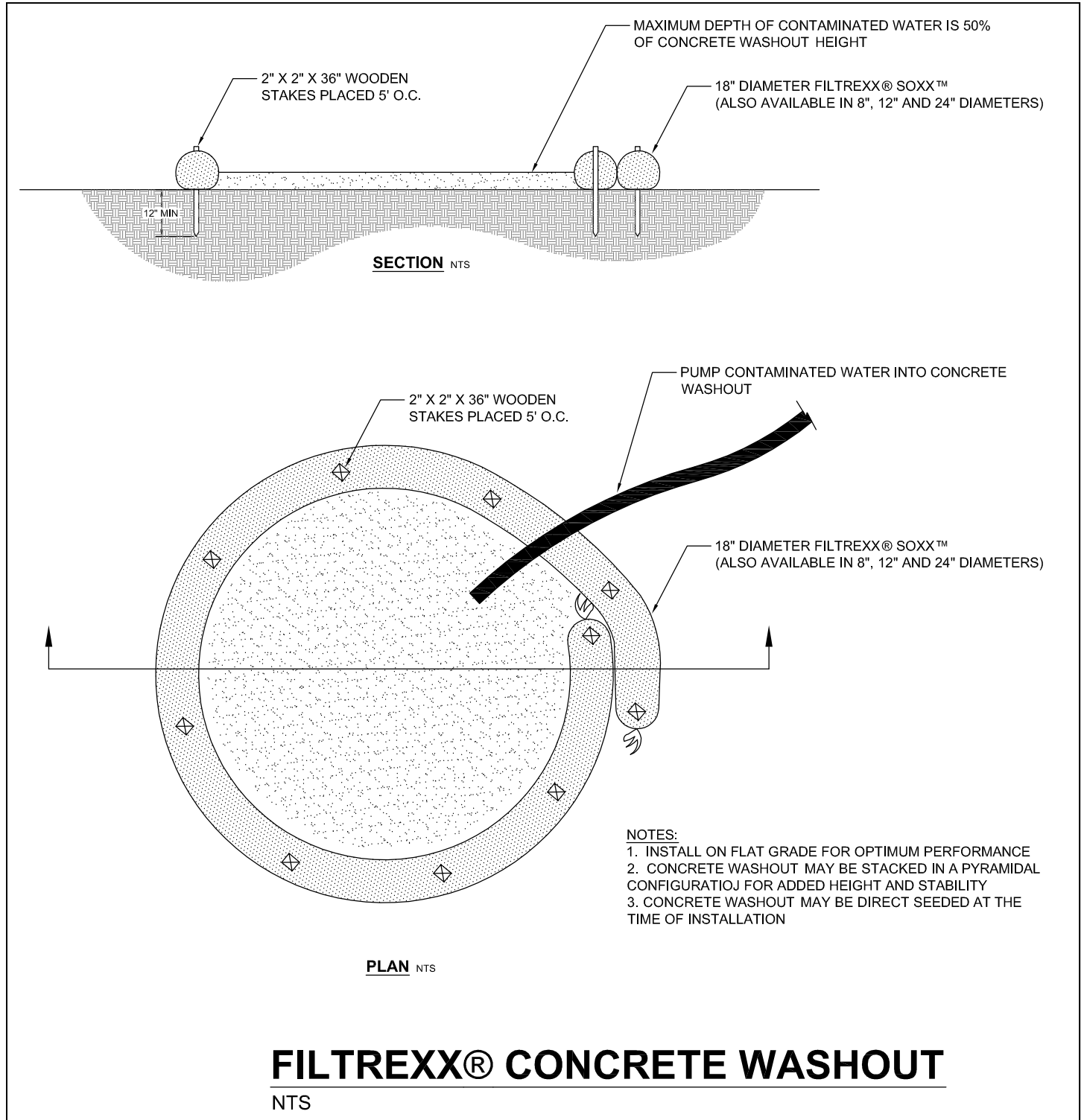

Figure 4.2. Engineering Design Drawing for Stacking Concrete Washout SoxX™ to Increase Design Height & Volume Capacity

